

 **PEINEMANN**  
EQUIPMENT

**BUILT FOR THE TOUGHEST JOBS**

# PEINEMANN 1-XLTC

**MANUAL MAY 2023**

[PEINEMANNEQUIPMENT.COM](https://www.peinemannequipment.com)



# CONTENT

|  |    |
|--|----|
| 1. GENERAL INFORMATION.....  | 4  |
| 1.1 Intended audience.....   | 4  |
| 1.2 Special information.....   | 4  |
| 1.3 Illustrations.....   | 4  |
| 1.4 Safety requirements.....   | 4  |
| 1.5 Personell training.....  | 4  |
| 1.6 Recommended tools.....   | 4  |
| 1.7 General system safety practices.....                                   | 5  |
| 1.8 Replacing components.....  | 6  |
| 1.9 Routine maintenance.....   | 6  |
| 1.10 Limited warranty.....   | 6  |
| 1.11 Hose sizes and pressure.....  | 5  |
| 1.12 SIR Regulations.....  | 6  |
| 1.13 Accountability.....   | 6  |
| 1.14 General terms and conditions.....                                     | 6  |
| 2. SAFETY INSTRUCTIONS.....  | 7  |
| 2.1 General.....   | 7  |
| 2.2 Steel lance and/or flex lance.....                                     | 7  |
| 3. CRIMP FITTING, NOZZLE, STOP SLEEVE, AND HOSE CATCHER CONFIGURATION..... | 8  |
| 4. GENERAL SPECIFICATIONS.....   | 10 |
| 4.1 Technical specifications.....  | 10 |
| 4.2 Components.....  | 11 |
| 5. INSTALLATION.....   | 12 |
| 5.1 Check items.....   | 12 |
| 5.2 Filling the oil lubricator.....  | 12 |
| 5.3 Adjusting the oil lubricator.....                                      | 12 |
| 5.4 Mounting the motor.....  | 12 |
| 5.5 Connecting the air hose.....   | 13 |
| 5.6 Setting the air pressure.....  | 13 |
| 5.7 Greasing the chain.....  | 13 |
| 6. OPERATIONS.....   | 14 |
| 6.1 Operating the 1-XLTC manually.....                                     | 14 |
| 6.1.1 Installing the lance and hose catcher.....                           | 14 |
| 6.1.2 Setting the friction.....  | 15 |
| 6.1.3 Setting the friction for horizontal use.....                         | 15 |
| 6.1.4 Mounting the end stop.....   | 16 |
| 6.1.5 Carrying strap.....  | 17 |
| 7. MAINTENANCE.....  | 18 |
| 7.1 Daily maintenance.....   | 18 |
| 7.2 Major maintenance.....   | 18 |
| 8. DECISION TREE.....  | 19 |
| 9. WARRANTY.....   | 21 |
| 10. APPENDIX.....  | 23 |
| 10.1 Schematic drawings  |    |
| 10.2 Parts list  |    |
| 10.3 Certifications  |    |
| 10.4 Declaration of Conformity   |    |

## **1. GENERAL INFORMATION**

### **1.1 Intended audience**

This manual is intended for field engineering, installation, operation, and repair personnel. Every effort has been made to ensure the accuracy of the information. However, Peinemann Equipment will not be held liable for errors in this manual or consequences arising from the misuse of this manual.

### **1.2 Special information**

Detailed descriptions of standard procedures, safety principles, and service operations are not included. Please note that this manual contains warnings about procedures which could damage equipment, make it unsafe, or cause PERSONAL INJURY. Anyone using service procedures or tools, whether or not recommended by Peinemann Equipment, must be thoroughly satisfied that neither personal safety nor equipment safety will be jeopardized.

All information in this manual is based upon the latest product information available at any time of printing. We reserve the right to make changes at any time without notice.

### **1.3 Illustrations**

Illustrations (figures) represent equipment components for identifying parts or establishing nomenclature. These figures may or may not be drawn to scale.

### **1.4 Safety requirements**

The 1-XLTC is installed and operated in a controlled environment involving hazardous situations. Therefore, proper maintenance is essential for safe and reliable operation. Procedures outlined in Peinemann Equipment manuals are the recommended methods for performing operations and maintenance.

### **1.5 Personnel training**

All personnel performing installation, operations, repair, or maintenance procedures on the equipment, or those in the vicinity of the equipment, should be trained to ensure their safety.

**! Personnel should wear protective gear during installation, maintenance, and operations.**

### **1.6 Recommended tools**

Service operations may require using tools designed specifically for the purpose described. Peinemann Equipment recommends that only those tools specified be used when stated. Ensure that personnel and equipment safety is not jeopardized when following service procedures.

## 1. GENERAL INFORMATION

### 1.7 General system safety practices

The equipment discussed in this manual may require or contains one or more utilities, such as electrical, hydraulic, pneumatic, or oil.

- Isolate energy sources before beginning work.
- Avoid performing maintenance or repairs while the equipment is in operation.
- Wear proper protective equipment during equipment installation, maintenance, or repair.

**! Read and follow the guidelines below before installing equipment or performing maintenance.**

### 1.8 Replacing components

- Verify that all components, such as cables and hoses, are tagged and labelled during assembly and disassembly of equipment to ensure correct installation.
- Replace failed or damaged components with Peinemann Equipment certified parts. Failure to do so could result in equipment damage or injury to personnel.
- Only use parts that are suitable for high-pressure and carry a valid test certificate.

### 1.9 Routine maintenance

Equipment must be maintained on a routine basis. See Ch.7 for maintenance guidelines.

**! Failure to conduct routine maintenance could result in equipment damage or injury to personnel.**

### 1.10 Limited warranty

Warranty provided will be void if the 1-XLTC or parts were either:

- Unauthorized modified repaired or serviced.
- Not properly maintained.
- Replacement parts not manufactured by Peinemann Equipment were utilized.

### 1.11 Hose sizes and pressures

The 1-XLTC is suitable for use with various hose sizes and pressures. However, the maximum throughput of the 1-XLTC is Ø20 millimeter (0.79 in). The most common hose sizes (3/2 - 8/4), hose catchers, nozzles and end stops are available from stock. Different lengths and shapes for the front lances are also available.

## **1. GENERAL INFORMATION**

### **1.12 SIR Regulations**

The 1-XLTC is a semi-automatic high-pressure flex lance transit machine, and current SIR regulations regarding high-pressure cleaning apply (or the applicable rules in the country where you are currently working). It is recommended to comply with SIR regulations. The general safety regulations apply, just as for other high-pressure cleaning activities. The nozzles to be used must follow the cleaning activity's nature. It is advised to refrain from using nozzles that exert a significant push or pull force.

### **1.13 Accountability**

Peinemann Equipment B.V. cannot be held accountable for any material and non-material damage caused during the installation and operation of the 1-XLTC. Therefore, users must carefully read this manual and handle the machine with care.

### **1.14 General terms and conditions**

“All offers, orders, assignments and agreements for the lease, sale and/or delivery of services by Peinemann Equipment B.V. are subject to Peinemann's General Terms and Conditions as lastly filed with the Chamber of Commerce and Industry in Rotterdam under number 24175469. The General Terms and Conditions can also be found on Peinemann.nl. Any other general terms and conditions are expressly rejected.”

## 2. SAFETY INSTRUCTIONS

### 2.1 General

- Use this machine only for the purpose it was developed and as instructed in the manual.
- This machine may only be used by qualified and trained personnel.
- The area around the work should be cordoned off to exclude untrained individuals.
- All personnel in the vicinity must wear appropriate protective clothing and eye and ear protection, per the specific requirements.
- Inspect the equipment for apparent damage or incorrect assembly. Wait to use the machine until this has been fixed.
- Rinse out the hoses before the nozzles are fitted to avoid any blockages.
- Check that all threaded connections are assembled tightly and leak-proof. Use stainless steel thread grease to avoid thread galling.
- Check that there are no blockages in the nozzles. If the nozzles are blocked, they must be cleaned or replaced.
- This machine must always be used with a foot pedal and/or dump valve that has been checked by an inspector and that automatically releases any water pressure when released.
- Water spray nozzles create a strong reactive force, and these forces can become unbalanced if a nozzle gets stuck. Use the equipment correctly to resist these forces.
- Check that all operating functions are working correctly before commencing high-pressure activities.
- Increase the pressure gradually when starting up the machine to ensure that everything is working correctly and that the equipment is appropriately balanced and positioned.
- Use fittings marked with the maximum working pressure and covered by a valid certificate. Stay within the maximum working pressure for each component in the system.

### 2.2 Steel lance and/or flex lance

- The farthest end of the bundle to be cleaned should be cordoned off with a 6 meter (19.69 in) radius. If there are other workers nearby, a screen should be used.
- The person closest to the nozzles must control the high-pressure water.
- The lance machine should be safeguarded against the reactive force of the water spray and the possibility of hydraulicking.
- The operator must take a position where he can see the pipe plate, but is far enough away not to be troubled by rebounding water spray during cleaning.
- Mechanical end stops must be fitted to ensure that the flex lance does not escape from the bundle.
- The length of a nozzle, including the end cap, on a high-pressure hose, must be the same or larger than the pipe's internal diameter to be cleaned to prevent the lance from turning. If not, a lead pipe must be installed between the end of the holes and the lance.
- It is recommended to use an anti-withdrawal device so that the machine cannot be pushed from the tube plate.
- When cleaning blocked pipes with small diameters, use a lance and hose diameter of less than 2/3 of the pipe diameter so the wastewater can escape. In addition, it is recommended to use an anti-withdrawal device to protect the operator against the hose being pushed back out of the pipe.
- High-pressure cleaning can damage pipes if the nozzles are not moved under pressure. Therefore, always ensure a cleaning protocol stating maximum water pressure.

### 3. CRIMP FITTING, NOZZLE, STOP SLEEVE, AND HOSE CATCHER CONFIGURATION

All Peinemann flex lance feeders such as the TLE, (X)LTC, TLX and Xs series must be operated with a correct nozzle, crimp fitting, stop sleeve and hose catcher configuration. Therefore, before starting operations, review the steps below to ensure a correct and safe operating configuration.

First, always use a nozzle with the same or larger diameter than the crimp fitting on the hose. When the nozzle has a smaller diameter than the crimp fitting, the risk of hydraulicking arises.



Nozzle diameter smaller than crimp fitting diameter = **incorrect**

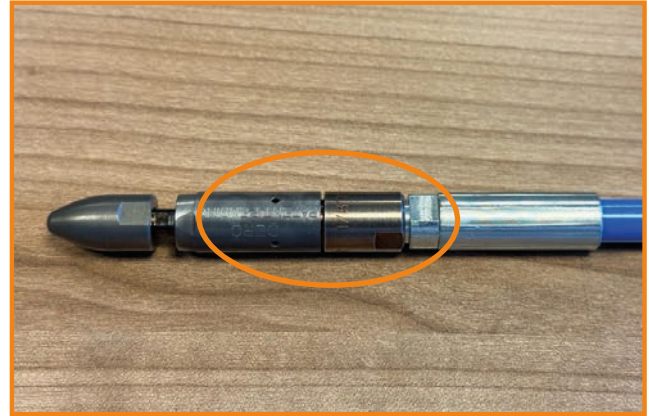

Nozzle diameter the same or larger than crimp fitting diameter = **correct**

Second, always use a hose with a stop sleeve (safety sleeve) at 5 centimeter (2 in) before the crimp fitting on the hose. Check that the stop sleeve has a large enough diameter to be safely stopped by the hose catcher. If a stop sleeve cannot be used (not recommended), then make sure that the crimp fitting has a large enough diameter to be safely stopped by the hose catcher. There is a risk of the hose coming through the hose catcher or getting stuck in the hose catcher when the stop sleeve and/or crimp fitting diameter is not significantly larger than the hose catcher diameter. The stop sleeve and/or crimp fitting is highly recommended to have at least a 3 millimeter (0.12 in) larger diameter than the hose catcher (=+1.5 mm around). If this is not the case, we recommend using a different configuration.



### 3. CRIMP FITTING, NOZZLE, STOP SLEEVE, AND HOSE CATCHER CONFIGURATION

Third, always physically check that the hose catcher stops the stop sleeve and/or crimp fitting (not recommended) on the hose. Do not only rely on the size engraved onto the crimp fitting, stop sleeve, and hose catcher. It is also recommended to measure if the crimp fitting and/or stop sleeve has a 3 millimeter (0.12 in) or larger diameter than the hose catcher (=+1.5 mm around).

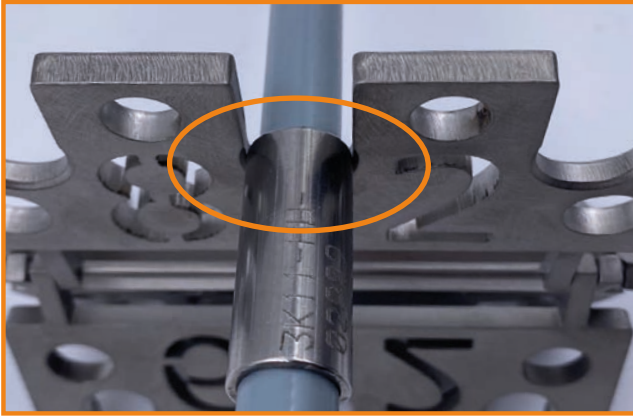

Stop sleeve diameter too small for the hose catcher = **incorrect**

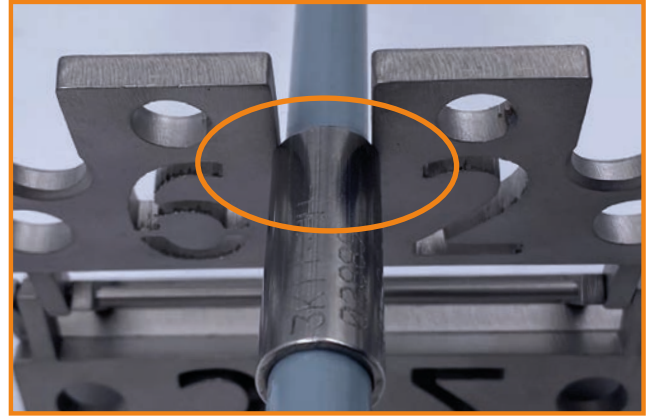

Stop sleeve diameter large enough for the hose catcher (stop sleeve diameter is min. 3mm larger than hose diameter (=+1.5mm around)) = **correct**

#### Special warning

Peinemann Equipment B.V. especially advises not to work with so called “Blast-Pro” or “Pro-lance” crimp fittings without the previously described stop sleeves fitted on the hose. These special crimp fittings are known to have a small diameter crimp fitting which could get stuck in the hose catcher and in worst case scenarios could pass the hose catcher if it returns in the flex lance cleaner at high speeds. Always add a correct stop sleeve to the hose if working with a “Blast-Pro” or “Pro-lance” coupling. Double-check that the stop sleeve diameter is minimally 3 millimeter (0.12 in) larger than the hose catcher after clamping the stop sleeve to the hose (=+1.5 mm around). The diameter of the stop sleeve might have decreased in the clamping process.



Typical “Blast-Pro” crimp fitting that could pass through the hose catcher



Always use a stop sleeve when using “Blast-Pro” or “Pro-Lance” crimp fitting

## 4. GENERAL SPECIFICATIONS

### 4.1 Technical specifications (approx.)

#### General

|                        |                                 |
|------------------------|---------------------------------|
| Length (drive unit)    | 32.0 cm (12.6 in)               |
| Width (drive unit)     | 38.0 cm (15.0 in)               |
| Height (drive unit)    | 26.0 cm (10.2 in)               |
| Weight (drive unit)    | 10 kg (22 lb)                   |
| Hose feed rate         | 40 - 70 cm/s (15.7 - 27.6 in/s) |
| Max. push/pull force   | 50 kg (110 lb)                  |
| Pitch adjustment range | N.a.                            |

#### Motor

|                         |                     |
|-------------------------|---------------------|
| Motor model Atlas Copco | LZB-33-L-AR009-50   |
| Max. output per motor   | 0.38 kW (0.51 hp)   |
| Min. air pressure       | 3.0 bar (43.5 psi)  |
| Operating air pressure  | 6.3 bar (91.4 psi)  |
| Max. air pressure       | 7.0 bar (101.5 psi) |
| Max. air consumption    | 14 l/s (29.7 cfm)   |
| Stall torque per motor  | 32 Nm (23.3 ft lb)  |
| Vane type               | Lubrication free    |

#### Hose specifications

|                             |                            |
|-----------------------------|----------------------------|
| Hose size                   | 3/2 - 8/4                  |
| Hose outer diameter         | 8 - 15 mm (0.31 - 0.59 in) |
| Max. hose coupling diameter | 20 mm (0.79 in)            |

## 4. GENERAL SPECIFICATIONS

### 4.2 Components

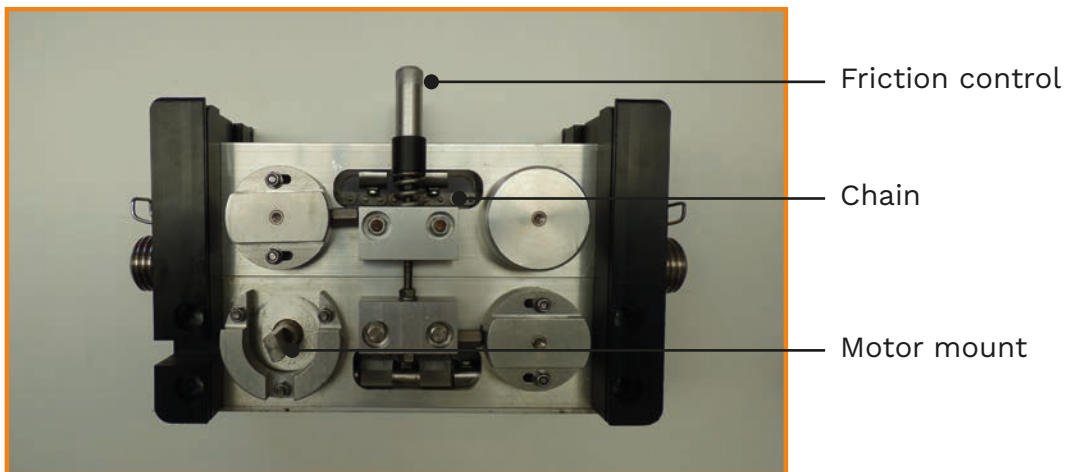
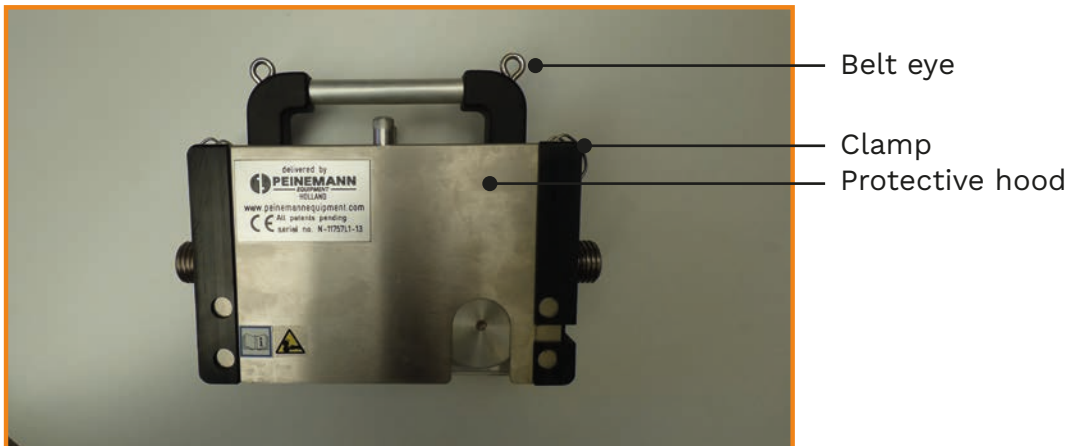

## 5. INSTALLATION

### 5.1 Check items

Check whether all required items are present. The following items should be present.

- 1-XLTC heart
- Oil lubricator
- Lubricator oil
- Special chain grease
- Optional products

### 5.2 Filling the oil lubricator

Fill the drum of the oil lubricator with the supplied oil. The oil drum is located on the exit side of the oil lubricator. Unscrew the drum by turning it counterclockwise, after which it can be filled along the open side. Screw the drum back into the block and tighten it firmly without additional tools. Always use the supplied oil for initial usage. For refilling, please use oil that is specifically intended for pneumatic tools.

### 5.3 Adjusting the oil lubricator

The oil lubricator can be adjusted using a screwdriver. Unscrewing the screw will cause drops to be released more frequently. Unscrew the regulating screw to such an extent that 1 drop per 5 seconds is released.

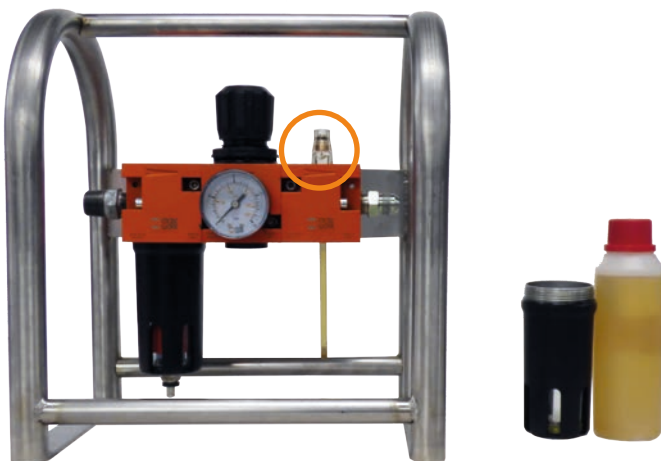

### 5.4 Mounting the motor

Remove the protective hood by loosening the clamps and lifting the protective hood. Unscrew the three nuts that hold the motor mount in place. Mount the motor to the machine. Ensure the machine's axle is aligned with the small fork of the air motor. Then place the motor mount back and secure it with the three nuts.

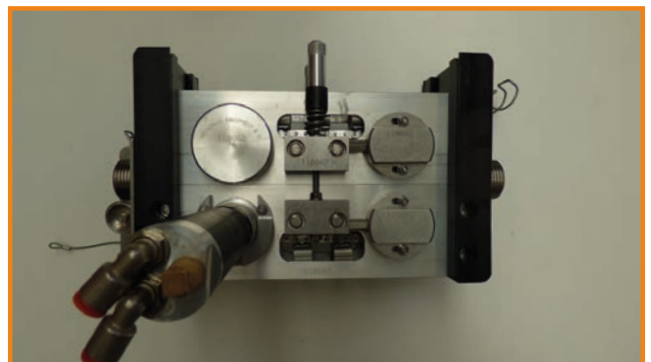
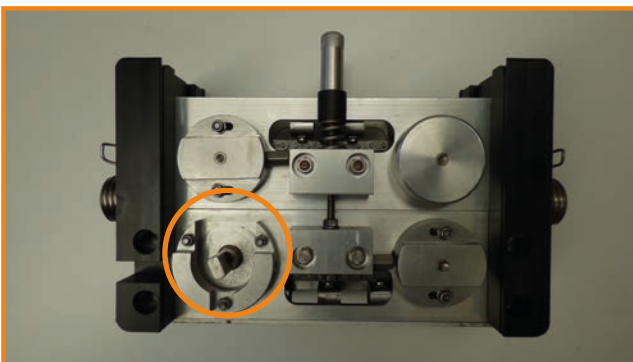

## 5. INSTALLATION

### 5.5 Connecting the air hose

Blow through the input air hose and connect it to the air supply unit and oil lubricator. Connect the output hose to the oil lubricator and motor.

### 5.6 Setting the air pressure

Set the air pressure between a minimum of 3 bar and a maximum of 6.3 bar.



### 5.7 Greasing the chain

Lubricate the chain with the supplied chain grease through openings in the side plates. Next, start the air supply unit and slowly run the chain by squeezing the lever on the motor. This allows the chain grease to spread throughout the chain. Then, stop the air supply unit and place the protective hood back.

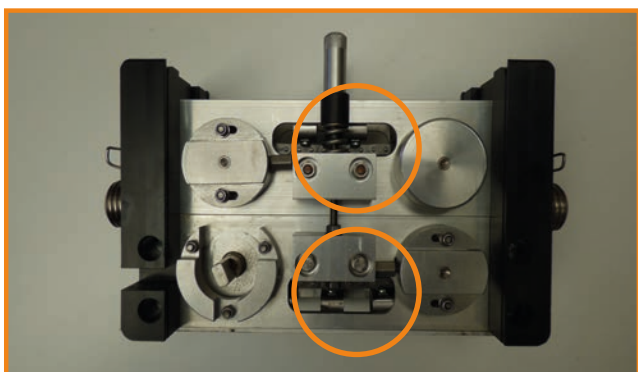

## 6. OPERATIONS

### 6.1 Operating the 1-XLTC manually

#### 6.1.1 Installing the lance and hose catcher

Relieve the friction controls by turning them counterclockwise. Next, connect the rear guiding hose to the back of the machine and manoeuvre the flex lance into the machine. Push the flex lance until it stops against the friction blocks. Then use the motor to force the flex lance further through the 1-XLTC until it is approx. 30 centimeter (11.81 in) out the front of the machine.

Attach the nozzle and the stinger to the flexible lance. Next, mount the correct size hose catcher and guide tube to the front of the 1-XLTC. Check that the hose collar cannot pass through the hose catcher. Pull the flex lance to check whether the hose catcher is functioning.



**! If the hose catcher is not attached correctly, the flex lance may pop out of the machine under high pressure.**

**! The chain is automatically kept at the correct tension. Always check the chain for wear and damage before usage. Also, check before use whether the chain runs smoothly without the motor.**

## 6. OPERATIONS

### 6.1.2 Setting the friction

There are multiple ways of setting the correct friction tension on the 1-XLTC. Peinemann Equipment recommends the following method. Hold the 1-XLTC vertically and activate the motor. The flex lance is pushed against the floor when the motor is activated. Turn the friction control until the machine almost detaches itself from the floor. The machine will now start slipping as soon as a reactive force higher than approx. 10 kg (22.05 lb) is produced.



### 6.1.3 Setting the friction for horizontal use

Follow the instructions in Ch.6.1.2 to set the initial friction tension. Then hold the 1-XLTC horizontally against the tube plate and perform a quick test against the tube plate. You can instantly find out whether the force is not too strong. The force is too strong when the operator is pushed away from the bundle.

**! Always check the friction setting before starting operations.**

## 6. OPERATIONS

### 6.1.4 Mounting the end stop

The maximum reach of the flex lance can be set by screwing the end stop onto the flex lance. The correct position for the end stop is determined by manoeuvring the hose in one of the bundle pipes until the nozzle extends beyond the tube plate. By screwing the end stop against the rear hose input on the flex lance, the length of the flex lance will never be too long, meaning that the nozzle will never protrude too far out of the pipe and create a potentially hazardous situation.

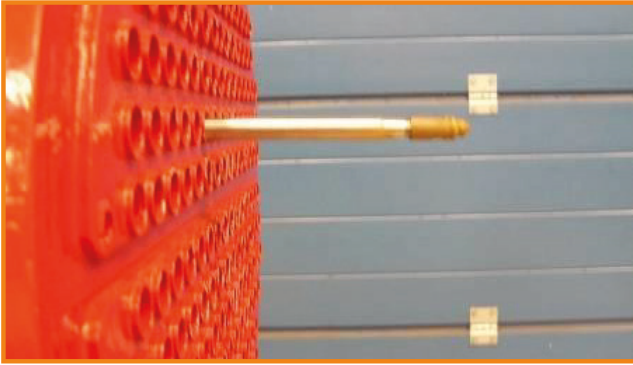

Incorrect

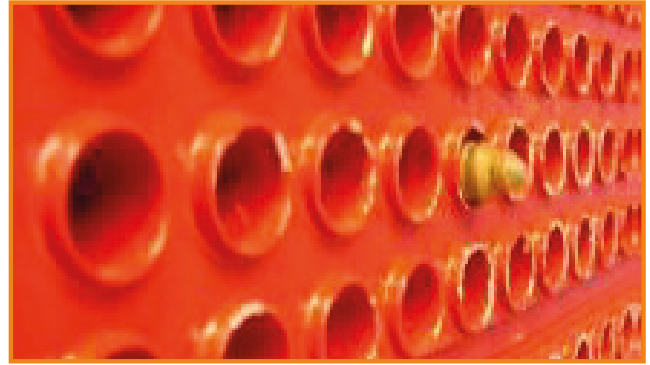

Correct

If the end stop touches the back of the machine during cleaning, the machine will start to slip, and the reverse movement can be started (check whether the end stop is actually touching the back of the machine). The reverse movement can be stopped if the stop sleeve on the flex lance touches the hose catcher in the machine and the 1-XLTC starts to slip. When working with the 1-XLTC, it is advised to use a stinger.

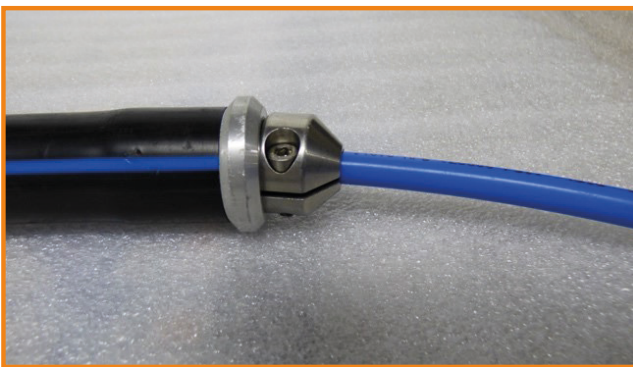

**! When cleaning a “U bundle” using a small hose with no stinger, this must be adjusted so that it cannot leave the pipe.**

## 6. OPERATIONS

### 6.1.5 Carrying strap

It is possible to operate the 1-XLTC by carrying it over your shoulders using a carrying strap.



**! It is advised to use the 1-XLTC with a balancer and anti-withdrawal device. This will take the weight of the machine out of your hands.**



## 7. MAINTENANCE

### 7.1 Daily maintenance

- Before use, check if the water separator in the oil lubricator is empty and that there is enough oil in the oil drum. The water separator is fitted with automatic water drainage, but it is essential to check that no water is present in the reservoir.
- After operating, clean the machine with water and/or cleaning agents.
- Grease the chain after operating.
- The motor must be filled with the supplied oil through the air inlet, after which the motor should briefly run with air. This allows the oil to spread throughout the rotor, which prevents the blades from sticking.
- Check the condition of the friction blocks. Replace if needed.

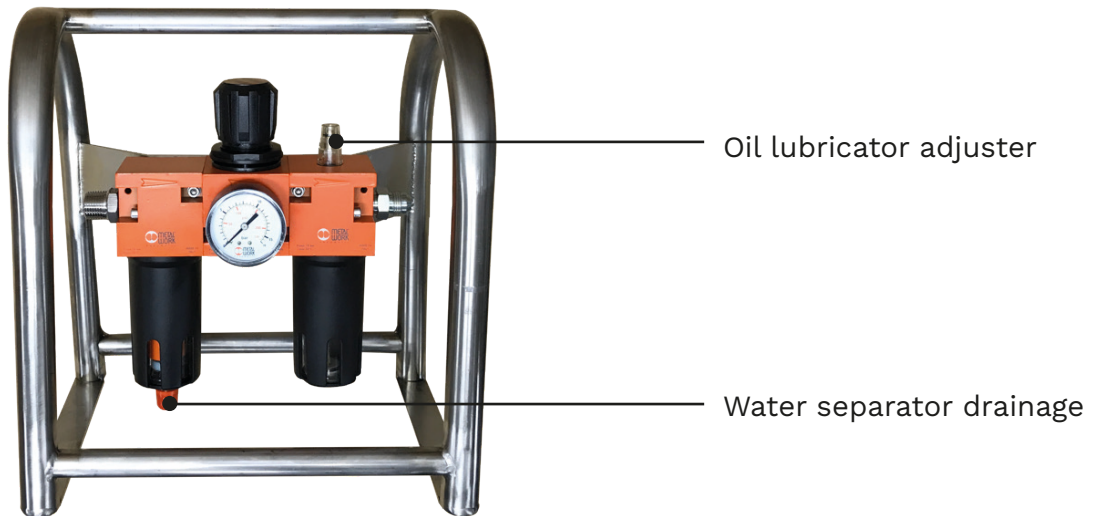

### 7.2 Major maintenance

Check the 1-XLTC by a qualified engineer every 500 service hours. If there is no record of service hours, then check the machine after one year. Contact Peinemann Equipment or one of our dealers for major maintenance and/or replacement of parts.

## 8. DECISION TREE

### Decision tree

An analysis of the reported high-pressure accidents over a period of many years has shown that most high-pressure accidents occur during manual cleaning with a flex lance or lance. It has therefore been decided to switch to a different method of decision-making before proceeding with manual high-pressure cleaning using a flex lance or lance. The purpose of the method described below is to drastically reduce this type of accident. This decision-making method has been the acceptable approach for this type of high-pressure cleaning work since 2008. The risks must be assessed before starting any cleaning work using a flex lance or lance. The cleaning method can be chosen on the basis of the following decision tree. Follow the steps in the decision tree from the point when the contract is secured until the work can be safely undertaken. The decision tree distinguishes six levels, with level 1 being the safest working method and level 6 representing a forbidden zone.

#### Level 1

The aim here is to use automatic equipment as far as possible, so that people need not be present in the immediate vicinity of the high-pressure spray cleaning work.

#### Level 2

If it is not possible to use automatic equipment, then the choice may be made to use semi-automatic equipment.

#### Level 3

If work with semi-automatic equipment is not possible, then a choice may be made to work manually with a flex lance. This must be fitted with a reducer sleeve where the flex lance is held in place by a hose collar. The hose collar must be attached to the item to be cleaned. The reducer sleeve must absorb the shock if the hose reverses out of control. This reducer sleeve must be clamped between 5 centimeter (1.97”) and 20 (7.87”) centimeter behind the pressure sleeve on the flex lance. The marking ring is not used in these situations. The certificate for this type of flex lance must state that it is fitted with a reducer sleeve and that the flex lance in question is only suitable to be used for cleaning with a hose collar. This means that the reducer sleeve is not a replacement for the marking ring, or vice versa. Check whether the flex lance with reducer sleeve is suitable for the hose collar being used. The spray operator must be aware of the risks associated with this working method and must wear personal protective equipment designed for the risks of working in this way.

Before proceeding to level 4 or 5: If it is not possible to work according to one of the three methods outlined above, then there must first be a consultation between the client and the cleaning company about the working method, including an assessment of the associated risks. Both parties must agree on the chosen working method. This agreement must be demonstrable by means of a document signed by both parties.

The following working methods for a flex lance are still permitted but are strongly discouraged because of the considerable risk.

## 8. DECISION TREE

### Level 4

If using one of the previous three methods is not possible, then the choice can be made to work manually with a flex lance that has been fitted with a lead pipe. The flex lance must be fitted with a marking ring. Note that a lead pipe should be used that is longer than the diameter of the pipe or tube in order to prevent any boomerang effect. The spray operator must wear comprehensive personal protective equipment designed to withstand the risks of this working method.

### Level 5

If working with a flex lance and lead pipe is not possible, then it is possible to work manually with a flex lance, which must be fitted with a marking ring. Note that the nozzle should be longer than the diameter of the pipe or tube in order to prevent any boomerang effect. Manual cleaning with a lance also comes under level 5. The spray operator must wear comprehensive personal protective equipment designed to withstand the risks of this working method.

### Level 6

Stop! Manual cleaning using a flex lance without a marking ring is prohibited.

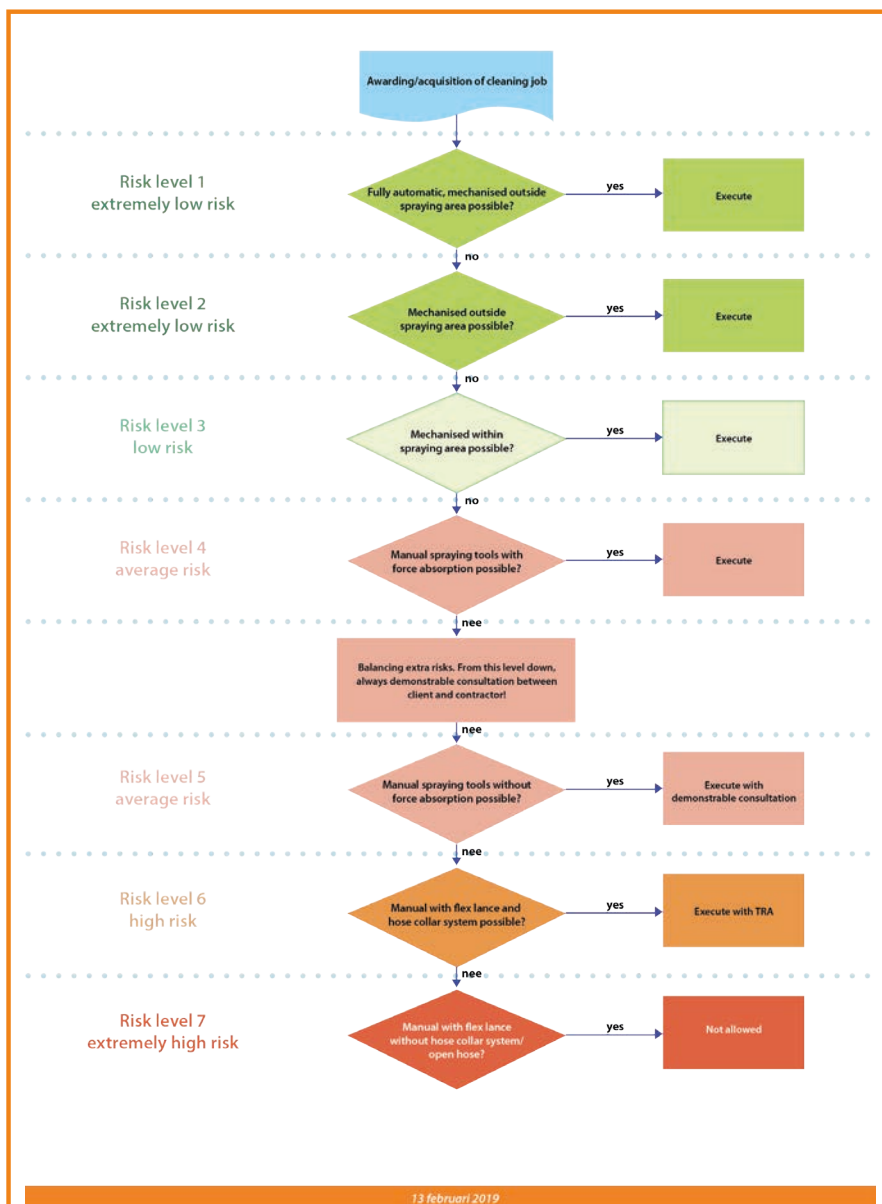

## 9. WARRANTY

### Warranty

1. Peinemann will provide warranties only if and insofar as this has been agreed explicitly in writing.

2. If and to the extent that a warranty has been agreed, Peinemann in respect of the Other Party warrants the soundness of the equipment and/or goods delivered by Peinemann, in the sense that if any shortcomings in the spare parts become clear during the warranty period and a complaint is submitted in good time, Peinemann will re-deliver spare parts at no cost by sending the spare parts to the Other Party. Peinemann will in principle not assemble the spare parts, unless parties explicitly agree otherwise in which case Peinemann will be compensated for all costs related to the assembly, travel costs included.

3. If and to the extent that a warranty has been agreed, this warranty will never exceed the warranty obligation which Peinemann's supplier has in respect of Peinemann and the opportunity for recovery which this supplier provides to Peinemann. Peinemann will be discharged in this respect if it assigns its claim to this third party to the Other Party. Warranty claims will not cause the Other Party's payment obligation to be suspended.

4. Peinemann does not warrant that equipment, spare parts, goods and/or services delivered by Peinemann are or will be fit for a particular purpose for which they are or will be used.

5. Agreed warranty on equipment, goods, spare parts and/or services delivered by Peinemann does not apply if defects are the result of:

- non-compliance with instructions given by Peinemann, including instructions regarding storage, placement, testing, installing, check and maintenance;
- improper use of the equipment, spare parts or goods or use not in accordance with the agreed or customary designated use;
- use of the equipment, spare parts or goods not in accordance with the corresponding manual;
- work performed to the equipment, spare parts, goods or services (within the warranty period) by the Other Party or third parties which have not been engaged by Peinemann, without Peinemann's permission;
- equipment, spare parts and/or goods being affected as a consequence of external causes, such as rain, water, heating, fire etc.;
- the Other Party not properly meeting one of its obligations under the agreement, or does not do so in good time;
- installation, assembly, modification or repair by the Other party or by third parties;
- defects in or unsuitability of spare parts or goods originating from or prescribed by the Other Party;
- defects in or unsuitability of materials or tools used by the Other Party;
- normal wear and tear.

## **9. WARRANTY**

6. No warranty is given on:

- equipment, spare parts and/or goods delivered that were not new at the time of delivery;
- the inspection and repair of equipment, spare parts or other goods of the Other Party;
- parts for which a manufacturer's warranty has been given.

### **Complaints**

1. The Other Party must inspect the delivered equipment, spare parts, goods and/or services on delivery and must submit any visible shortcomings to Peinemann in writing no later than seven days after the delivery, failing which any claim against Peinemann will lapse.
2. Complaints regarding other shortcomings must be submitted in writing within seven days after they have become manifest, subject to lapsing of any claim against Peinemann.
3. Complaints regarding insignificant deviations in terms of quality, quantity, size, finishing etc. and/or deviations on the aforementioned terms that are permissible on the market or technically unavoidable, as well as complaints regarding the circumstance that certain equipment or goods have been removed from the assortment, will not be deemed founded by Peinemann.

# 10. APPENDIX

## 10.1 Schematic drawings

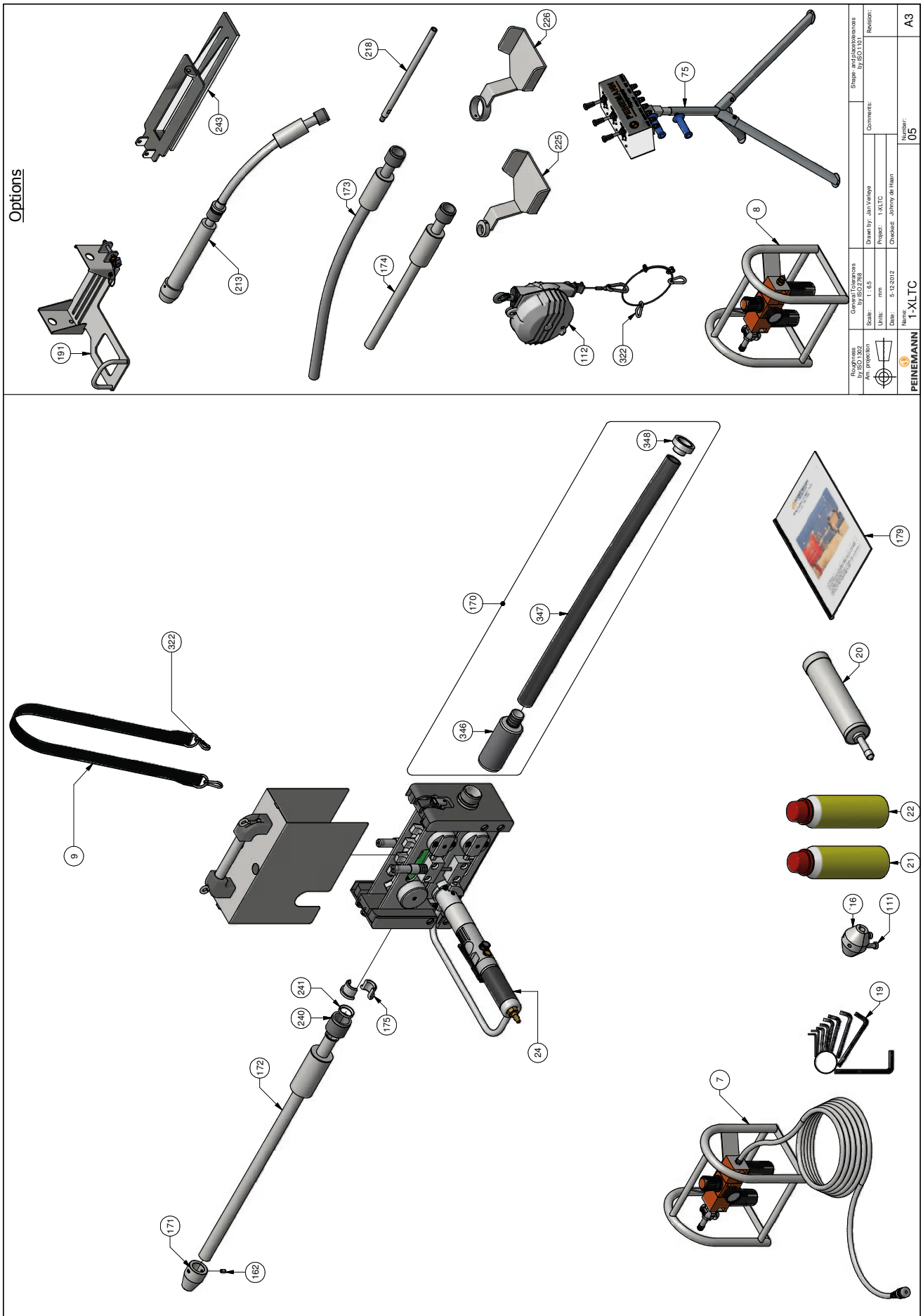

Options

|   |   |   |
|---|---|---|
| Drawing No.<br>18002900<br>An. projection<br>Scale: 1 : 0,5<br>Units: mm<br>Date: 5.12.2012 | Comments:<br>Drawn by: Jan Verhey<br>Project: 1-XLTC<br>Checked: Johnny de Haan | Shape and dimensions<br>18002900<br>Revision: |
| Name: 1-XLTC<br>Number: 05  |   | A3  |

# 10. APPENDIX

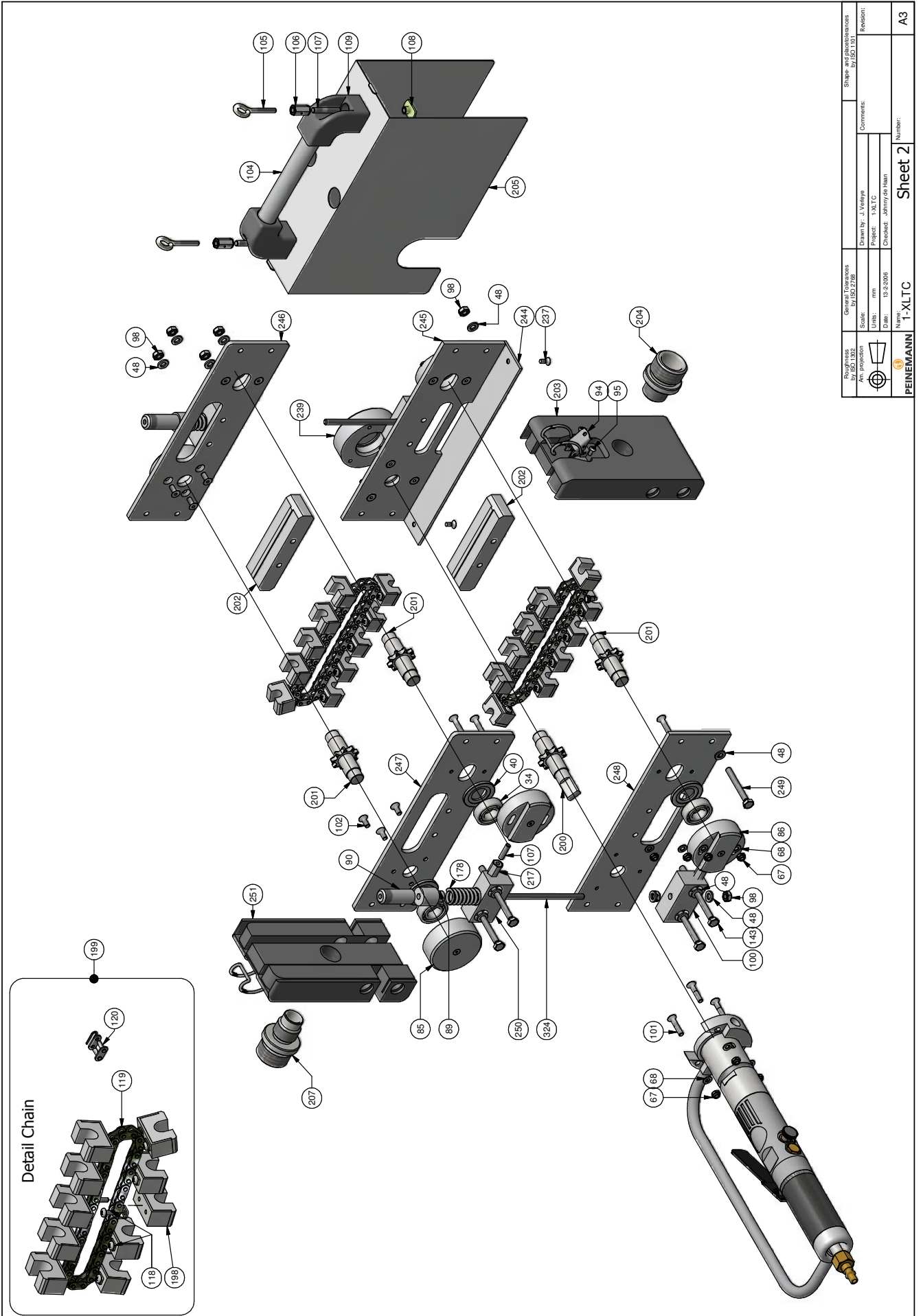

|                                   |   |
|-----------------------------------|---|
| General Tolerances<br>by ISO 2768 | Shaping and photochemicals<br>by ISO 1101 |
| Scale:<br>mm                      | Comments:                                 |
| Units:<br>mm                      | Drawn by: J. Veljko                       |
| Date:<br>13-2-2008                | Project: 1-XLTC                           |
| Name:<br>Johannes Veljko          | Checked: Johannes Veljko                  |
| Number:<br>Sheet 2                | Revision:                                 |
| PEINEMANN<br>1-XLTC               | Number:<br>A3                             |

## 10. APPENDIX

### 10.2 Parts list

| PARTS  |                | PART NO<br>DRAWING |
|--|----------------|--------------------|
| DESCRIPTION  | PART<br>NUMBER |                    |
| Replacement motor  | 110001         | 264                |
| Replacement motor fast                                     | 110002         | 265                |
| Replacement motor for automatic use                        | 110003         | 267                |
| Replacement motor for automatic use fast                   | 110004         | 330                |
| Quick change out motor                                     | 110005         | 260                |
| Quick change out motor fast                                | 110006         | 261                |
| Quick change out motor with protection bar and handle      | 110007         | 24                 |
| Quick change out motor fast with protection bar and handle | 110008         | 25                 |
| Quick change out motor for automatic use complete          | 110009         | 263                |
| Quick change out motor fast for automatic use              | 110010         | 328                |
| Parker motor 072 complete                                  | 110011         | 182                |
| End stop 4/2 Ø8MM  | 110021         | 16                 |
| End stop 5/2 Ø9,5MM  | 110022         | 16                 |
| End stop 6/2 Ø11,5MM                                       | 110023         | 16                 |
| Front indexing piece 4/2 Ø12MM                             | 110024         | 14                 |
| Front indexing piece 5/2 Ø14MM                             | 110025         | 14                 |
| Front indexing piece 6/2 Ø16MM                             | 110026         | 14                 |
| Front indexing piece 6/2 Ø20MM                             | 110026A        | 14                 |
| Belt   | 110027         | 9                  |
| Allen key set  | 110028         | 19                 |
| Brass hose union 3/8"                                      | 110029         | 69                 |
| Air lubricator oil 0,2 L                                   | 110030         | 21                 |
| Special chain grease fluid 0,2 L                           | 110031         | 22                 |
| Handgun for grease and oil                                 | 110032         | 20                 |
| Air supply unit complete                                   | 110033         | 7                  |
| Air supply unit complete automatic use                     | 110034         | 8                  |
| Set of bearings (9PCS)                                     | 110038         | 34                 |
| Balancer adjustable 10-14Kg                                | 110039         | 112                |
| Stinger 1000Bar 200MM M7                                   | 110040         | 218                |
| Stinger 1000Bar 200MM 1/8" BSP                             | 110041         | 218                |
| Stinger 1000Bar 200MM 1/4" BSP                             | 110042         | 218                |
| Stinger 1000Bar 200MM 1/16" NPT                            | 110043         | 218                |
| Stinger 1000Bar 200MM 1/8" NPT                             | 110044         | 218                |
| Stinger 1000Bar 200MM 1/4" NPT                             | 110045         | 218                |
| Mounting block handle                                      | 110054         | 109                |
| Aluminum barr for handle                                   | 110055         | 104                |
| Closing lever stainless cover                              | 110056         | 94                 |
| Drive shaft  | 110057         | 33                 |

## 10. APPENDIX

| PARTS                                 |                | PART NO<br>DRAWING |
|---------------------------------------|----------------|--------------------|
| DESCRIPTION                           | PART<br>NUMBER |                    |
| Drive shaft Fast                      | 110057A        |                    |
| Clamp motor support                   | 110060         | 42                 |
| Bearinghouse small                    | 110061         | 85                 |
| Bearinghouse large                    | 110062         | 239                |
| Bearinghouse with chainadjustment     | 110063         | 86                 |
| Seal ring bearinghouse                | 110064         | 40                 |
| Bearing for axle Ø15MM                | 110065         | 34                 |
| Aluminium side block underpart        | 110066         | 100                |
| Aluminium spring support              | 110067         | 250                |
| Spring endstop                        | 110069         | 89                 |
| Friction adjusmentknob                | 110070         | 90                 |
| Screw M4x10 taptite                   | 110073         | 118                |
| Bolt A2 M5x12 countersunk sockethead  | 110074         | 102                |
| Bolt A2 M5x25 countersunk sockethead  | 110075         | 101                |
| Bolt A2 M5x55 sockethead              | 110076         | 66                 |
| Bolt A2 M6x20 sockethead              | 110077         | 111                |
| Studbolt A2 M6x10                     | 110078         | 162                |
| Studbolt A2 M6x20                     | 110079         | 107                |
| Studbolt A2 M6x160                    | 110080         | 87                 |
| Bolt A2 M6x50                         | 110081         | 97                 |
| Bolt A2 M6x80                         | 110082         | 99                 |
| Lockingnut M5                         | 110083         | 67                 |
| Nut M6                                | 110084         | 98                 |
| Long nut M6 x 15                      | 110085         | 217                |
| long nut M6 x 18                      | 110086         | 106                |
| Welding nut M6                        | 110087         | 108                |
| Washer M5                             | 110088         | 68                 |
| Washer M6                             | 110089         | 48                 |
| Retainer washer Ø17                   | 110090         | 36                 |
| Screw Ø3x10                           | 110091         | 237                |
| Screw Ø3,9x13                         | 110092         | 95                 |
| Eyebolt M6x30x10                      | 110093         | 105                |
| Carabine hook Ø6 x 60                 | 110094         | 322                |
| Excentric ring guide tube             | 110097         | 13                 |
| Aluminium handle rear guide hose      | 110098         | 343                |
| Chain for 10 friction blocks          | 110102         | 119                |
| Chain link                            | 110103         | 120                |
| Stainless bracket for air supply unit | 110105         | 57                 |
|                                       |                |                    |

## 10. APPENDIX

| PARTS                                    |             | PART NO<br>DRAWING |
|--|-------------|--------------------|
| DESCRIPTION                              | PART NUMBER |                    |
| Air pressure reducer                     | 110106      | 60                 |
| Pressure reducer adjustment knob         | 110107      | 64                 |
| Air lubricator                           | 110108      | 62                 |
| Flow regulator for air lubricator        | 110109      | 123                |
| Drum for air lubricator                  | 110110      | 58                 |
| Waterseparator                           | 110111      | 61                 |
| Drum for water separator                 | 110112      | 59                 |
| Pressure gauge                           | 110113      | 63                 |
| O-ring Ø3 x 8                            | 110114      | 256                |
| Reducer nipple 3/8"x1/2"                 | 110115      | 193                |
| Hose nipple Ø10x1/4"                     | 110116      | 268                |
| Hose nipple Ø10x3/8"                     | 110117      | 122                |
| Quickconnection female x 1/4"f           | 110118      | 125                |
| Air hose Ø10 L=5M                        | 110119      | 65                 |
| Hose clamp Ø15                           | 110120      | 126                |
| Motor support standard                   | 110121      | 39                 |
| Lever for air motor                      | 110122      | 254                |
| Pin for air motor                        | 110123      | 255                |
| Drive shaft complete standard            | 110124      | 234                |
| Drive shaft complete fast                | 110125      | 325                |
| Bronze cover for drive shaft             | 110126      | 37                 |
| Fill ring motor                          | 110127      | 35                 |
| Rotor for motor                          | 110128      | 257                |
| Planetary gear standard                  | 110129      | 32                 |
| Planetary gear fast                      | 110130      | 55                 |
| Housing for planetary gear standard      | 110131      | 38                 |
| Housing for planetary gear standard fast | 110132      | 56                 |
| Air outlet motor                         | 110133      | 30                 |
| Air supply pipe                          | 110134      | 28                 |
| Quick connection 1/4"BSP Male            | 110135      | 27                 |
| JIC 8 3/4" 90° airconnection             | 110136      | 270                |
| Coupling JIC 8 x 1/4"modified left       | 110137      | 185                |
| Coupling JIC 8 x 1/4"modified right      | 110138      | 51                 |
| Brass ring Ø18x14x4                      | 110139      | 121                |
| Brass ring Ø18x14x8                      | 110139A     | 370                |
| Safety bar quick change out motor        | 110140      | 52                 |
| Safety bar quick change out motor fast   | 110141      | 53                 |
| Rubber handle quick change out motor     | 110142      | 29                 |
|  |             |                    |

## 10. APPENDIX

| PARTS   |                | PART NO<br>DRAWING |
|---|----------------|--------------------|
| DESCRIPTION   | PART<br>NUMBER |                    |
| Rubber handle quick change out motor fast                 | 110143         | 259                |
| Parker motor 072  | 110144         | 183                |
| Motor support Parker motor                                | 110145         | 184                |
| Connector Parker motor                                    | 110146         | 46                 |
| Silencer Parker motor                                     | 110147         | 224                |
| Lockingpin Ø10 x 70                                       | 110150         | 72                 |
| Cable for lockingpin                                      | 110151         | 73                 |
| Replacement motor slow                                    | 210001         | 266                |
| Replacement motor for automatic use slow                  | 210002         | 331                |
| Quick change out motor slow                               | 210006         | 262                |
| Quick change out motor slow with safety bar and handle    | 210008         | 44                 |
| Quick change out motor slow for automatic use             | 210010         | 329                |
| Hydraulic motor omm32 complete                            | 210011         | 23                 |
| Straight guide tube Ø25MM 400MM XL                        | 210012         | 174                |
| Straight guide tube Ø25MM 700MM XL                        | 210013         | 172                |
| Straight guide tube Ø48MM 800MM (2 parts)                 | 210013A        |                    |
| Straight guide tube Ø25MM 1200MM XL                       | 210014         | 172                |
| Footplate 48MM  | 210015         | 226                |
| Bent guide tube Ø25MM 700MM XL                            | 210016         | 173                |
| Bent guide tube Ø48MM 800MM (2 parts)                     | 210016A        | 213                |
| Rear protection hose XL                                   | 210017         | 170                |
| Hose catcher XL 4/2 Ø8,5MM                                | 210018A        | 175                |
| Hose catcher XL 5/2 Ø10MM                                 | 210018B        | 175                |
| Hose catcher XL 6/2 Ø12MM                                 | 210018C        | 175                |
| Hose catcher XL 6/4 Ø13MM                                 | 210018         | 175                |
| Hose catcher XL 8/2 Ø14MM                                 | 210019         | 175                |
| Hose catcher XL8/4 Ø15MM                                  | 210020         | 175                |
| End stop 6/4 Ø12,5MM                                      | 210021         | 16                 |
| End stop 8/2 Ø13,5MM                                      | 210022         | 16                 |
| End stop 8/4 Ø14,5MM                                      | 210023         | 16                 |
| Front indexing piece XL 6/2                               | 210024A        | 171                |
| Front indexing piece XL 6/4                               | 210024         | 171                |
| Front indexing piece XL 8/2                               | 210025         | 171                |
| Front indexing piece XL 8/4                               | 210026         | 171                |
| Users manual XI   | 210035         | 179                |
| Chain stainless steel with 6/2 - 8/4 single blocks XL SET | 210036SS       | 199                |
| Chain stainless steel with 4/2 - 6/2 single blocks XL SET | 210036SSA      | 199                |
| Chain guide block multilene XL                            | 210037         | 202                |
|   |                |                    |

## 10. APPENDIX

| PARTS  |                | PART NO<br>DRAWING |
|--|----------------|--------------------|
| DESCRIPTION                                  | PART<br>NUMBER |                    |
| Chain guide block aluminium XL               | 210037A        | 202                |
| Bottomplate aluminium XL                     | 210046         | 244                |
| Headblock front XL                           | 210047         | 251                |
| Headblock rear XL                            | 210048         | 203                |
| Sideplate underpart left XL                  | 210049         | 248                |
| Sideplate underpart right XL                 | 210050         | 245                |
| Sideplate upperpart left XL                  | 210051         | 247                |
| Sideplate upperpart right XL                 | 210052         | 246                |
| Stainless safety cover XLTC                  | 210053         | 205                |
| Axle with chainwheel and motor connection XL | 210058         | 200                |
| Axle with chainwheel XL                      | 210059         | 201                |
| Spring XL                                    | 210068         | 178                |
| Connection nipple front XL                   | 210071         | 207                |
| Connection nipple back XL                    | 210072         | 204                |
| Studbolt A2 M6x170                           | 210080         | 324                |
| Bolt A2 M6x60                                | 210081         | 249                |
| Bolt A2 M6x90                                | 210082         | 143                |
| Connection nut protection tube XL            | 210095         | 240                |
| Locking ring protection tube XL              | 210096         | 241                |
| Aluminium handle rear guide hose XL          | 210098         | 346                |
| Aluminium endpiece guide hose XL             | 210099         | 348                |
| Hose for protection hose XL                  | 210101         | 347                |
| Friction block 6/2 till 8/4 XL               | 210104         | 198                |
| Friction block 4/2 till 6/2 XL               | 210104A        | 198                |
| Planetary gear slow                          | 210130         | 43                 |
| Housing for planetary gear slow              | 210132         | 187                |
| Safety bar quick change out motor slow       | 210141         | 54                 |
| Rubber handle quick change out motor slow    | 210143         | 258                |
| Hydraulic motor omm32                        | 210144         | 45                 |
| Motor support OMM32 hydraulic motor          | 210145         | 47                 |
| Connector OMM32 hydraulic motor              | 210146         | 186                |
| Stainless mountingframe XLTC                 | 210148         | 191                |
| Connection plate XL                          | 210149         | 243                |

## **10. APPENDIX**

**10.3 Certifications**

**10.4 Declaration of Conformity**

